

CoroMill® 345

Vlakfrees voor hoge productiviteit

Toepassing

- Vlakfreesen
- Voordraaien tot nadraaien

ISO toepassingsgebied:



Voordelen en kenmerken

- Lage kosten per component dankzij wisselplaten met acht snijkanten
- Hoge productiviteit – met inwendig koelmiddel is ook bij veeleisende materialen een hoge productiviteit mogelijk
- Veilig bewerken dankzij met onderlegplaat beschermde wisselplaatzittingen en een stijve freesbody
- Geoptimaliseerde machinebezettingsgraad en productiviteit met vier verschillende vertandingen
- Breed toepassingsgebied – gebruik het zelfde concept voor verschillende toepassingen



www.sandvik.coromant.com/coromill345

Koppelingen

- Coromant Capto®
- Doorn
- Cilindrische schacht

Wisselplaten

- Acht snijkanten
- Wiper-wisselplaten voor uitstekende oppervlakteafwerking bij hoge voeding per tand

Inwendige koelvloeistof

Koelmiddeltoevoer naar elke wisselplaatzitting waarborgt een goede spaanafvoer en goede prestaties, ook bij het bewerken van veeleisende materialen.

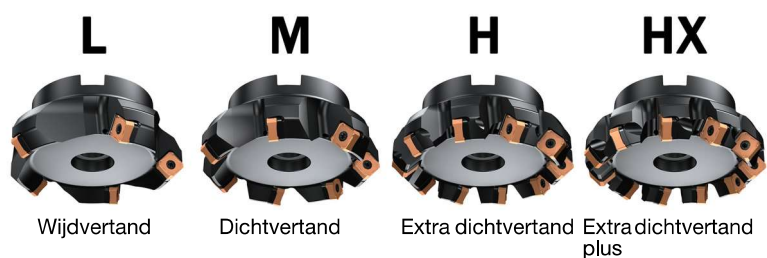
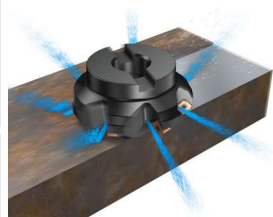

15



18

CoroMill® 345 vlakfrees

Coromant Capto® - inwendige koelmiddeltoevoer

KAPR 45°

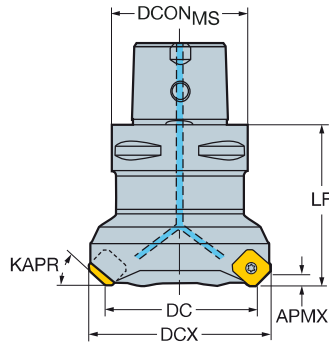

							Afmetingen, mm							
DC	CZC _{MS}	APMX _{FFW}	CNSC	Bestelnummer		DCON _{MS}	DCX	LF	NM	KG	RPMX	CICT	MIID	
40,0	13	C4	6,00	3	4	345-040C4-13M	40,0	54,1	60,0	3,0	0,89	19600	4	345R-1305
50,0	13	C5	6,00	3	4	345-050C5-13M	50,0	64,1	60,0	3,0	1,39	17500	4	345R-1305
	13	C6	6,00	3	4	345-050C6-13M	63,0	64,1	60,0	3,0	1,80	17500	4	345R-1305
	13	C5	6,00	3	5	345-050C5-13H	50,0	64,1	60,0	3,0	1,48	17500	5	345R-1305
	13	C6	6,00	3	5	345-050C6-13H	63,0	64,1	60,0	3,0	1,79	17500	5	345R-1305
63,0	13	C5	6,00	3	5	345-063C5-13M	50,0	77,1	60,0	3,0	1,53	15500	5	345R-1305
	13	C6	6,00	3	5	345-063C6-13M	63,0	77,1	60,0	3,0	1,91	15500	5	345R-1305
	13	C5	6,00	3	6	345-063C5-13H	50,0	77,1	60,0	3,0	1,62	15500	6	345R-1305
	13	C6	6,00	3	6	345-063C6-13H	63,0	77,1	60,0	3,0	1,97	15500	6	345R-1305
80,0	13	C6	6,00	3	6	345-080C6-13M	63,0	94,1	70,0	3,0	2,46	13700	6	345R-1305
	13	C8	6,00	3	6	345-080C8-13M	80,0	94,1	70,0	3,0	3,32	13700	6	345R-1305
	13	C6	6,00	3	8	345-080C6-13H	63,0	94,1	70,0	3,0	2,54	13700	8	345R-1305
100,0	13	C8	6,00	3	7	345-100C8-13M	80,0	114,1	80,0	3,0	4,01	12200	7	345R-1305

Reserve onderdelen

Wisselplaat-schroef	Onderlegplaat	Onderlegplaat schroef
416.1-834	5322 474-01	5512 090-11

Ga voor de complete lijst van reserveonderdelen naar www.sandvik.coromant.com



CoroMill® 345 vlakfrees

Doornbevestiging - inwendige koelvoelstoftoevoer

STDNO
KAPR

ISO6462
45°

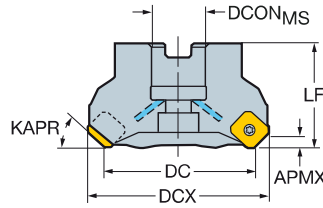
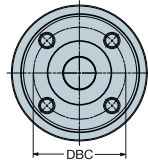

							Afmetingen, mm											
DC	CZC _{MS}	APMX _{FW}	CNSC	Bestelnummer	DCON _{MS}	ISO	DBC	DCX	LF	NM	KG	RPM	CICT	MID				
40.0	13	22	6.00	1	3	345-040Q22-13L	22.0	A	54.1	45.0	3.0	0.68	19600	3	345R-1305			
	13	22	6.00	1	4	345-040Q22-13M	22.0	A	54.1	45.0	3.0	0.67	19600	4	345R-1305			
50.0	13	22	6.00	1	3	345-050Q22-13L	22.0	A	64.1	45.0	3.0	0.82	17500	3	345R-1305			
	13	22	6.00	1	4	345-050Q22-13M	22.0	A	64.1	45.0	3.0	0.78	17500	4	345R-1305			
	13	22	6.00	1	5	345-050Q22-13H	22.0	A	64.1	45.0	3.0	0.82	17500	5	345R-1305			
63.0	13	22	6.00	1	4	345-063Q22-13L	22.0	A	77.1	45.0	3.0	0.98	15500	4	345R-1305			
	13	22	6.00	1	5	345-063Q22-13M	22.0	A	77.1	45.0	3.0	0.94	15500	5	345R-1305			
	13	22	6.00	1	6	345-063Q22-13H	22.0	A	77.1	45.0	3.0	0.60	15500	6	345R-1305			
	13	22	6.00	1	7	345-063Q22-13HX	22.0	A	77.1	45.0	3.0	1.03	15500	7	345R-1305			
80.0	13	27	6.00	1	4	345-080Q27-13L	27.0	A	94.1	50.0	3.0	1.65	13700	4	345R-1305			
	13	27	6.00	1	6	345-080Q27-13M	27.0	A	94.1	50.0	3.0	1.72	13700	6	345R-1305			
	13	27	6.00	1	8	345-080Q27-13H	27.0	A	94.1	50.0	3.0	1.72	13700	8	345R-1305			
	13	27	6.00	1	9	345-080Q27-13HX	27.0	A	94.1	50.0	3.0	1.76	13700	9	345R-1305			
100.0	13	32	6.00	1	5	345-100Q32-13L	32.0	A	114.1	50.0	3.0	2.30	12200	5	345R-1305			
	13	32	6.00	1	7	345-100Q32-13M	32.0	A	114.1	50.0	3.0	2.29	12200	7	345R-1305			
	13	32	6.00	1	10	345-100Q32-13H	32.0	A	114.1	50.0	3.0	2.31	12200	10	345R-1305			
	13	32	6.00	1	11	345-100Q32-13HX	32.0	A	114.1	50.0	3.0	2.38	12200	11	345R-1305			
125.0	13	40	6.00	1	6	345-125Q40-13L	40.0	B	139.1	63.0	3.0	3.64	10900	6	345R-1305			
	13	40	6.00	1	8	345-125Q40-13M	40.0	B	139.1	63.0	3.0	3.48	10900	8	345R-1305			
	13	40	6.00	1	12	345-125Q40-13H	40.0	B	139.1	63.0	3.0	3.63	10900	12	345R-1305			
	13	40	6.00	1	14	345-125Q40-13HX	40.0	B	139.1	63.0	3.0	3.64	10900	14	345R-1305			
160.0	13	40S	6.00	0	7	345-160Q40-13L	40.0	C	66.7	174.1	63.0	3.0	4.59	9600	7	345R-1305		
	13	40S	6.00	0	10	345-160Q40-13M	40.0	C	66.7	174.1	63.0	3.0	4.50	9600	10	345R-1305		
	13	40S	6.00	0	12	345-160Q40-13H	40.0	C	66.7	174.1	63.0	3.0	4.72	9600	12	345R-1305		
	13	40S	6.00	0	16	345-160Q40-13HX	40.0	C	66.7	174.1	63.0	3.0	4.58	9600	16	345R-1305		
200.0	13	60	6.00	0	12	345-200Q60-13M	60.0	C	101.6	214.1	63.0	3.0	10.60	8600	12	345R-1305		
	13	60	6.00	0	16	345-200Q60-13H	60.0	C	101.6	214.1	63.0	3.0	6.64	8600	16	345R-1305		
250.0	13	60	6.00	0	14	345-250Q60-13M	60.0	C	101.6	264.1	63.0	3.0	10.36	7700	14	345R-1305		
	13	60	6.00	0	18	345-250Q60-13H	60.0	C	101.6	264.1	63.0	3.0	10.79	7700	18	345R-1305		

Reserve onderdelen				
DC	Schroef met platte kop	Wisselplaat-schroef	Onderlegplaat	Onderlegplaat schroef
40.00-63.00	5512-073-01	416.1-834	5322 474-01	5512 090-11
80.00	5512-073-02	416.1-834	5322 474-01	5512 090-11
100.00	5512-073-05	416.1-834	5322 474-01	5512 090-11
125.00-160.00	5512-098-03	416.1-834	5322 474-01	5512 090-11
250.00		416.1-834	5322 474-01	5512 090-11

Ga voor de complete lijst van reserveonderdelen naar www.sandvik.coromant.com



I8



L2



M1



N23



N9



N15

CoroMill® 345 vlakfrees

Cilindrische schacht - interne koelmiddeltoevoer

KAPR 45°

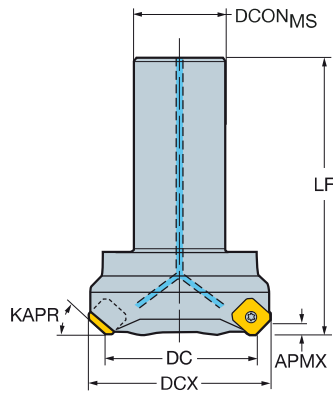

						Afmetingen, mm						
DC	CZC _{MS}	APMX _{FFW}	CNSC	Bestelnummer	DCON _{MS}	DCX	LF	NM	KG	RPMX	CICT	MIID
40,0	13	32	6,00	1 4	345-040A32-13M	32,0	54,1	120,0	3,0	1,26	19600	4 345R-1305
50,0	13	32	6,00	1 3	345-050A32-13L	32,0	64,1	120,0	3,0	1,41	17500	3 345R-1305
	13	32	6,00	1 4	345-050A32-13M	32,0	54,1	120,0	3,0	1,41	17500	4 345R-1305

Reserve onderdelen

Wisselplaat-schroef	Onderlegplaat	Onderlegplaat-schroef
416.1-834	5322 474-01	5512 090-11

Ga voor de complete lijst van reserveonderdelen naar www.sandvik.coromant.com

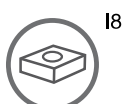

I8



L2



N23



N9



N15

